

ASM-3XXX Series Blades

Used in the following Schäfer / Megomat machines:

ASM-3XXX

Available ASM-3XXX Blade Form Geometries Include:



Universal



V-Style

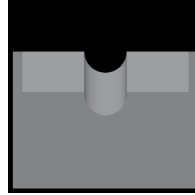

Die-Type



Standard "MV" Tooling Setup

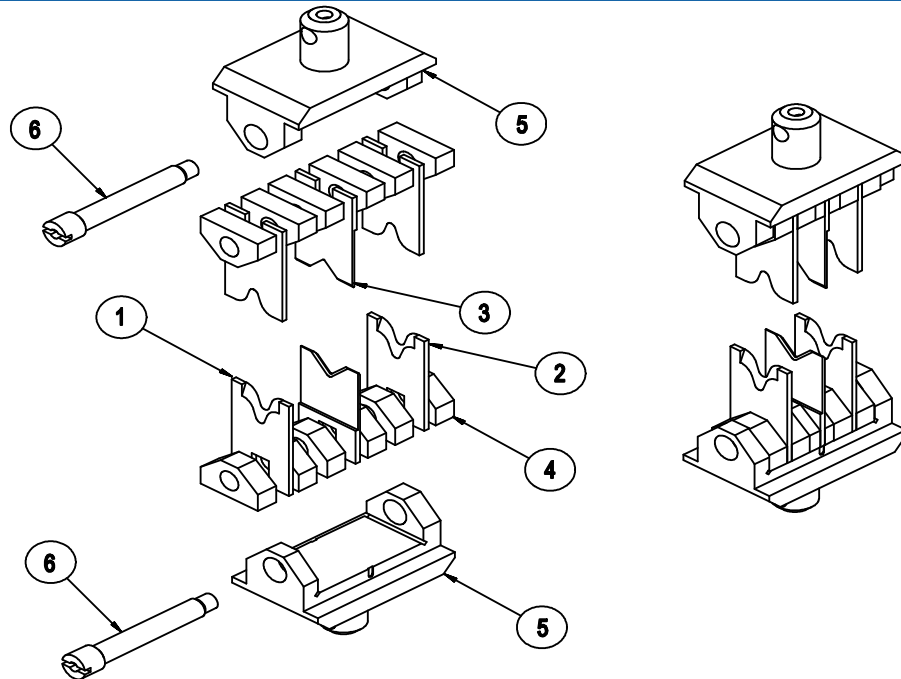

No.	Part Description	Qty.	No.	Part Description	Qty.
1	MV Stripping Blade-Short	2	5	ASM-3XXX Toolholder	2
2	MV Stripping Blade-Long	2	6	ASM-3XXX Toolholder Pin	2
3	MVC Cut-off Blade	2			
4	ASM-3XXX Spacer	-			

ASM-3XXX Series Blades

Used in the following *Schäfer / Megomat* machines:

ASM-3XXX

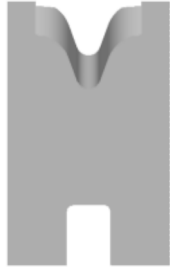

MV Stripping Blades

Mechtrix Description	Mechtrix Part Number	Blade Form (in)	Diameter (mm)	OEM Part Number
MV-0.30 Stripping Blade-Short	12429	0.01181	0.30	-
MV-0.30L Stripping Blade-Long	12430			-
MV-0.55 Stripping Blade-Short	12431	0.02165	0.55	-
MV-0.55L Stripping Blade-Long	12432			-
MV-0.78 Stripping Blade-Short	12433	0.03071	0.78	-
MV-0.78L Stripping Blade-Long	12434			-
MV-1.13 Stripping Blade-Short	13863	0.04449	1.13	-
MV-1.13L Stripping Blade-Long	13862			-
MV-1.65 Stripping Blade-Short	08663	0.06496	1.65	-
MV-1.65L Stripping Blade-Long	08662			-
MV-2.09 Stripping Blade-Short	09420	0.08228	2.09	-
MV-2.09L Stripping Blade-Long	09419			-
MV-2.53 Stripping Blade-Short	09074	0.09961	2.53	-
MV-2.53L Stripping Blade-Long	09073			-
MV-3.01 Stripping Blade-Short	08824	0.11850	3.01	-
MV-3.01L Stripping Blade-Long	08823			-
MV-3.49 Stripping Blade-Short	12435	0.13740	3.49	-
MV-3.49L Stripping Blade-Long	12436			-
MV-4.37 Stripping Blade-Short	12437	0.17205	4.37	-
MV-4.37L Stripping Blade-Long	12438			-



MVC Cut-off Blades

Mechtrix Description	Mechtrix Part Number	Blade Form (in)	Diameter (mm)	OEM Part Number
MVC Cut-off Blades	08664	-	-	-

ASM-3XXX Series Blades

Used in the following Schäfer / Megomat machines:

ASM-3XXX

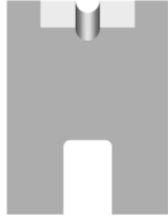

Standard "MD" Tooling Setup

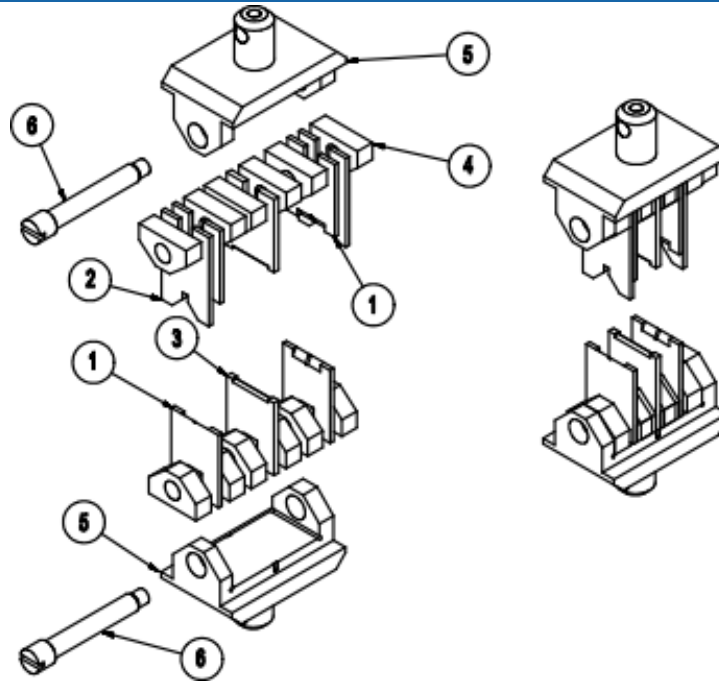

No.	Part Description	Qty.	No.	Part Description	Qty.
1	MD Stripping Blade	4	5	ASM-3XXX Toolholder	2
2	MDG Wire Guide	2	6	ASM-3XXX Toolholder Pin	2
3	MDC Cut-off Blade	2			
4	ASM-3XXX Spacer	-			



MDC Cut-off Blades (Megomat-USA)

Mechtrix Description	Mechtrix Part Number	Blade Form (in)	Diameter (mm)	OEM Part Number
MDC Cut-off Blade	08907	-	-	M.013.0186.400
MDC-1.0 Cut-off Blade	11904	-	-	M.013.0186.410

ASM-3XXX Series Blades

Used in the following *Schäfer / Megomat* machines:

ASM-3XXX

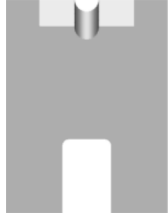

MD Stripping Blades (Megomat-USA)

Mechtrix Description	Mechtrix Part Number	Blade Form (in)	Diameter (mm)	OEM Part Number
MD-0.4 Stripping Blade	10382	0.01575	0.40	M.013.0250.404
MD-0.5 Stripping Blade	16077	0.01969	0.50	M.013.0251.405
MD-0.6 Stripping Blade	13362	0.02362	0.60	M.013.0252.406
MD-0.7 Stripping Blade	13159	0.02756	0.70	M.013.0253.407
MD-0.8 Stripping Blade	09953	0.03150	0.80	M.013.0254.408
MD-0.9 Stripping Blade	11213	0.03543	0.90	M.013.0255.409
MD-1.0 Stripping Blade	08929	0.03937	1.00	M.013.0256.410
MD-1.1 Stripping Blade	09470	0.04331	1.10	M.013.0257.411
MD-1.2 Stripping Blade	08930	0.04724	1.20	M.013.0258.412
MD-1.3 Stripping Blade	09954	0.05118	1.30	M.013.0259.413
MD-1.4 Stripping Blade	09447	0.05512	1.40	M.013.0260.414
MD-1.5 Stripping Blade	08931	0.05906	1.50	M.013.0261.415
MD-1.6 Stripping Blade	08984	0.06299	1.60	M.013.0262.416
MD-1.7 Stripping Blade	11719	0.06693	1.70	M.013.0263.417
MD-1.8 Stripping Blade	08932	0.07087	1.80	M.013.0264.418
MD-1.9 Stripping Blade	10342	0.07480	1.90	M.013.0265.419
MD-2.0 Stripping Blade	09071	0.07874	2.00	M.013.0266.420
MD-2.1 Stripping Blade	11214	0.08268	2.10	M.013.0266.421
MD-2.2 Stripping Blade	10762	0.08661	2.20	M.013.0267.422
MD-2.3 Stripping Blade	16116	0.09055	2.30	-
MD-2.4 Stripping Blade	09498	0.09449	2.40	M.013.0268.424
MD-2.5 Stripping Blade	11827	0.09843	2.50	-
MD-2.6 Stripping Blade	09684	0.10236	2.60	M.013.0269.426
MD-2.7 Stripping Blade	16431	0.10630	2.70	-
MD-2.8 Stripping Blade	09072	0.11024	2.80	M.013.0270.428
MD-2.9 Stripping Blade	22601	0.11417	2.90	-
MD-3.0 Stripping Blade	11003	0.11811	3.00	M.013.0271.430
MD-3.1 Stripping Blade	19852	0.12205	3.10	-
MD-3.2 Stripping Blade	09685	0.12598	3.20	M.013.0272.432
MD-3.3 Stripping Blade	23155	0.12992	3.30	-
MD-3.4 Stripping Blade	09182	0.13386	3.40	M.013.0273.434
MD-3.5 Stripping Blade	23156	0.13780	3.50	-
MD-3.6 Stripping Blade	11684	0.14173	3.60	M.013.0274.436
MD-3.7 Stripping Blade	19850	0.14567	3.70	-
MD-3.8 Stripping Blade	13072	0.14961	3.80	M.013.0275.438
MD-3.9 Stripping Blade	16890	0.15354	3.90	-
MD-4.0 Stripping Blade	12000	0.15748	4.00	M.013.0276.440
MD-4.1 Stripping Blade	23157	0.16142	4.10	-
MD-4.2 Stripping Blade	12107	0.16535	4.20	M.013.0277.442
MD-4.3 Stripping Blade	23158	0.16929	4.30	-
MD-4.4 Stripping Blade	20804	0.17323	4.40	M.013.0278.444
MD-4.5 Stripping Blade	23159	0.17717	4.50	-
MD-4.6 Stripping Blade	14117	0.18110	4.60	M.013.0279.446
MD-4.7 Stripping Blade	23160	0.18504	4.70	-
MD-4.8 Stripping Blade	17093	0.18898	4.80	M.013.0280.448
MD-4.9 Stripping Blade	23161	0.19291	4.90	-
MD-5.0 Stripping Blade	20805	0.19685	5.00	M.013.0281.450

ASM-3XXX Series Blades

Used in the following *Schäfer / Megomat* machines:

ASM-3XXX

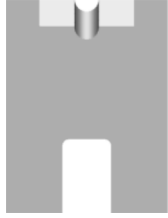

MD Stripping Blades (Megomat-USA)

Mechtrix Description	Mechtrix Part Number	Blade Form (in)	Diameter (mm)	OEM Part Number
MD-0.4 Stripping Blade	10382	0.01575	0.40	M.013.0250.404
MD-0.5 Stripping Blade	16077	0.01969	0.50	M.013.0251.405
MD-0.6 Stripping Blade	13362	0.02362	0.60	M.013.0252.406
MD-0.7 Stripping Blade	13159	0.02756	0.70	M.013.0253.407
MD-0.8 Stripping Blade	09953	0.03150	0.80	M.013.0254.408
MD-0.9 Stripping Blade	11213	0.03543	0.90	M.013.0255.409
MD-1.0 Stripping Blade	08929	0.03937	1.00	M.013.0256.410
MD-1.1 Stripping Blade	09470	0.04331	1.10	M.013.0257.411
MD-1.2 Stripping Blade	08930	0.04724	1.20	M.013.0258.412
MD-1.3 Stripping Blade	09954	0.05118	1.30	M.013.0259.413
MD-1.4 Stripping Blade	09447	0.05512	1.40	M.013.0260.414
MD-1.5 Stripping Blade	08931	0.05906	1.50	M.013.0261.415
MD-1.6 Stripping Blade	08984	0.06299	1.60	M.013.0262.416
MD-1.7 Stripping Blade	11719	0.06693	1.70	M.013.0263.417
MD-1.8 Stripping Blade	08932	0.07087	1.80	M.013.0264.418
MD-1.9 Stripping Blade	10342	0.07480	1.90	M.013.0265.419
MD-2.0 Stripping Blade	09071	0.07874	2.00	M.013.0266.420
MD-2.1 Stripping Blade	11214	0.08268	2.10	M.013.0266.421
MD-2.2 Stripping Blade	10762	0.08661	2.20	M.013.0267.422
MD-2.3 Stripping Blade	16116	0.09055	2.30	-
MD-2.4 Stripping Blade	09498	0.09449	2.40	M.013.0268.424
MD-2.5 Stripping Blade	11827	0.09843	2.50	-
MD-2.6 Stripping Blade	09684	0.10236	2.60	M.013.0269.426
MD-2.7 Stripping Blade	16431	0.10630	2.70	-
MD-2.8 Stripping Blade	09072	0.11024	2.80	M.013.0270.428
MD-2.9 Stripping Blade	22601	0.11417	2.90	-
MD-3.0 Stripping Blade	11003	0.11811	3.00	M.013.0271.430
MD-3.1 Stripping Blade	19852	0.12205	3.10	-
MD-3.2 Stripping Blade	09685	0.12598	3.20	M.013.0272.432
MD-3.3 Stripping Blade	23155	0.12992	3.30	-
MD-3.4 Stripping Blade	09182	0.13386	3.40	M.013.0273.434
MD-3.5 Stripping Blade	23156	0.13780	3.50	-
MD-3.6 Stripping Blade	11684	0.14173	3.60	M.013.0274.436
MD-3.7 Stripping Blade	19850	0.14567	3.70	-
MD-3.8 Stripping Blade	13072	0.14961	3.80	M.013.0275.438
MD-3.9 Stripping Blade	16890	0.15354	3.90	-
MD-4.0 Stripping Blade	12000	0.15748	4.00	M.013.0276.440
MD-4.1 Stripping Blade	23157	0.16142	4.10	-
MD-4.2 Stripping Blade	12107	0.16535	4.20	M.013.0277.442
MD-4.3 Stripping Blade	23158	0.16929	4.30	-
MD-4.4 Stripping Blade	20804	0.17323	4.40	M.013.0278.444
MD-4.5 Stripping Blade	23159	0.17717	4.50	-
MD-4.6 Stripping Blade	14117	0.18110	4.60	M.013.0279.446
MD-4.7 Stripping Blade	23160	0.18504	4.70	-
MD-4.8 Stripping Blade	17093	0.18898	4.80	M.013.0280.448
MD-4.9 Stripping Blade	23161	0.19291	4.90	-
MD-5.0 Stripping Blade	20805	0.19685	5.00	M.013.0281.450

ASM-3XXX Series Blades

Used in the following Schäfer / Megomat machines:

ASM-3XXX



MDG Wire Guides (Megomat-USA)

Mechtrix Description	Mechtrix Part Number	Guide Form (in)	Diameter (mm)	OEM Part Number
MDG-0.6 Wire Guide	09956	0.02362	0.60	M.013.0300.406
MDG-0.7 Wire Guide	16078	0.02756	0.70	M.013.0301.407
MDG-0.8 Wire Guide	14789	0.03150	0.80	M.013.0302.408
MDG-0.9 Wire Guide	14790	0.03543	0.90	M.013.0303.409
MDG-1.0 Wire Guide	15905	0.03937	1.00	M.013.0304.410
MDG-1.1 Wire Guide	13363	0.04331	1.10	M.013.0305.411
MDG-1.2 Wire Guide	13144	0.04724	1.20	M.013.0306.412
MDG-1.3 Wire Guide	11215	0.05118	1.30	M.013.0307.413
MDG-1.4 Wire Guide	09955	0.05512	1.40	M.013.0308.414
MDG-1.5 Wire Guide	13076	0.05906	1.50	M.013.0309.415
MDG-1.6 Wire Guide	09957	0.06299	1.60	M.013.0310.416
MDG-1.7 Wire Guide	11333	0.06693	1.70	M.013.0311.417
MDG-1.8 Wire Guide	08933	0.07087	1.80	M.013.0312.418
MDG-1.9 Wire Guide	10771	0.07480	1.90	M.013.0313.419
MDG-2.0 Wire Guide	08934	0.07874	2.00	M.013.0314.420
MDG-2.1 Wire Guide	10772	0.08268	2.10	M.013.0315.421
MDG-2.2 Wire Guide	08935	0.08661	2.20	M.013.0316.422
MDG-2.3 Wire Guide	09471	0.09055	2.30	M.013.0317.423
MDG-2.4 Wire Guide	08936	0.09449	2.40	M.013.0318.424
MDG-2.5 Wire Guide	10343	0.09843	2.50	M.013.0319.425
MDG-2.6 Wire Guide	08937	0.10236	2.60	M.013.0320.426
MDG-2.7 Wire Guide	09699	0.10630	2.70	M.013.0321.427
MDG-2.8 Wire Guide	09499	0.11024	2.80	M.013.0322.428
MDG-2.9 Wire Guide	11741	0.11417	2.90	M.013.0323.429
MDG-3.0 Wire Guide	08938	0.11811	3.00	M.013.0324.430
MDG-3.1 Wire Guide	13258	0.12205	3.10	-
MDG-3.2 Wire Guide	09185	0.12598	3.20	M.013.0325.432
MDG-3.3 Wire Guide	18233	0.12992	3.30	-
MDG-3.4 Wire Guide	08939	0.13386	3.40	M.013.0326.434
MDG-3.5 Wire Guide	13813	0.13780	3.50	-
MDG-3.6 Wire Guide	09700	0.14173	3.60	M.013.0327.436
MDG-3.7 Wire Guide	18927	0.14567	3.70	-
MDG-3.8 Wire Guide	08940	0.14961	3.80	M.013.0328.438
MDG-3.9 Wire Guide	23162	0.15354	3.90	-
MDG-4.0 Wire Guide	09075	0.15748	4.00	M.013.0329.440
MDG-4.1 Wire Guide	13918	0.16142	4.10	-
MDG-4.2 Wire Guide	09701	0.16535	4.20	M.013.0330.442
MDG-4.3 Wire Guide	23163	0.16929	4.30	-
MDG-4.4 Wire Guide	13385	0.17323	4.40	M.013.0331.444
MDG-4.5 Wire Guide	09702	0.17717	4.50	-
MDG-4.6 Wire Guide	09076	0.18110	4.60	M.013.0332.446
MDG-4.7 Wire Guide	23164	0.18504	4.70	-
MDG-4.8 Wire Guide	12708	0.18898	4.80	M.013.0333.448
MDG-4.9 Wire Guide	19435	0.19291	4.90	-
MDG-5.0 Wire Guide	11528	0.19685	5.00	M.013.0334.450
MDG-5.1 Wire Guide	16232	0.20079	5.10	-
MDG-5.2 Wire Guide	13097	0.20472	5.20	M.013.0335.452
MDG-5.3 Wire Guide	21764	0.20866	5.30	-
MDG-5.4 Wire Guide	12707	0.21260	5.40	M.013.0336.454

ASM-3XXX Series Blades

Used in the following Schäfer / Megomat machines:

ASM-3XXX

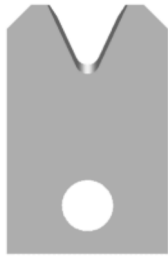

Standard "MVAG" Tooling Setup

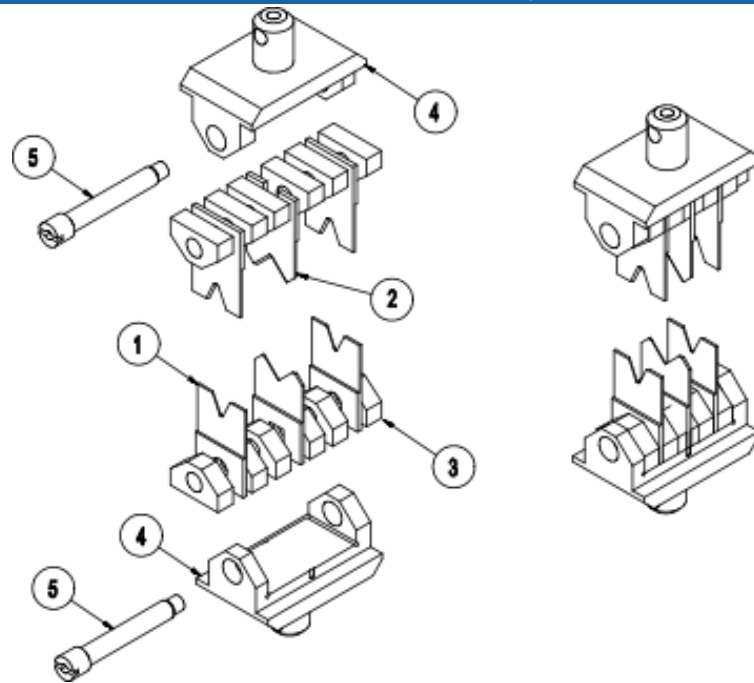

No.	Part Description	Qty.	No.	Part Description	Qty.
1	MVAG Stripping Blade	4	5	ASM-3XXX Toolholder Pin	2
2	MVCE Cut-off Blade	2	6		
3	ASM-3XXX Spacer	-			
4	ASM-3XXX Toolholder	2			



MVAG Stripping Blades

Mechtrix Description	Mechtrix Part Number	Blade Form	Diameter (in)	Diameter (mm)	OEM Part Number
MVAG-0.6 Stripping Blade	23269		0.02362	0.60	6.013.0501.506
MVAG-0.7 Stripping Blade	23270		0.02756	0.70	6.013.0502.507
MVAG-0.8 Stripping Blade	23271		0.03150	0.80	6.013.0503.508
MVAG-0.9 Stripping Blade	20256		0.03543	0.90	6.013.0504.509
MVAG-1.0 Stripping Blade	20073		0.03937	1.00	6.013.0505.510
MVAG-1.1 Stripping Blade	21262		0.04331	1.10	6.013.0506.511
MVAG-1.2 Stripping Blade	23272		0.04724	1.20	6.013.0507.512
MVAG-1.3 Stripping Blade	20257		0.05118	1.30	6.013.0508.513
MVAG-1.4 Stripping Blade	23273		0.05512	1.40	6.013.0509.514
MVAG-1.5 Stripping Blade	23274		0.05906	1.50	6.013.0510.515
MVAG-1.6 Stripping Blade	20258		0.06299	1.60	6.013.0511.516
MVAG-1.7 Stripping Blade	23275		0.06693	1.70	6.013.0512.517
MVAG-1.8 Stripping Blade	23276		0.07087	1.80	6.013.0513.518
MVAG-1.9 Stripping Blade	23277		0.07480	1.90	6.013.0514.519

Continued on Next Page

ASM-3XXX Series Blades

Used in the following *Schäfer / Megomat* machines:

ASM-3XXX

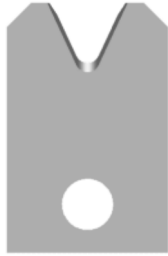

MVAG Stripping Blades (continued)

Mechtrix Description	Mechtrix Part Number	Blade Form Diameter		OEM Part Number
		(in)	(mm)	
MVAG-2.0 Stripping Blade	20259	0.07874	2.00	6.013.0515.520
MVAG-2.1 Stripping Blade	23278	0.08268	2.10	6.013.0516.521
MVAG-2.2 Stripping Blade	23279	0.08661	2.20	6.013.0517.522
MVAG-2.3 Stripping Blade	23280	0.09055	2.30	6.013.0518.523
MVAG-2.4 Stripping Blade	23281	0.09449	2.40	6.013.0519.524
MVAG-2.5 Stripping Blade	23282	0.09843	2.50	6.013.0520.525
MVAG-2.6 Stripping Blade	23283	0.10236	2.60	6.013.0521.526
MVAG-2.7 Stripping Blade	23284	0.10630	2.70	6.013.0522.527
MVAG-2.8 Stripping Blade	23285	0.11024	2.80	6.013.0523.528
MVAG-2.9 Stripping Blade	23286	0.11417	2.90	6.013.0524.529
MVAG-3.0 Stripping Blade	20885	0.11811	3.00	6.013.0525.530
MVAG-3.2 Stripping Blade	23287	0.12598	3.20	6.013.0526.532
MVAG-3.4 Stripping Blade	23288	0.13386	3.40	6.013.0527.534
MVAG-3.6 Stripping Blade	23289	0.14173	3.60	6.013.0528.536
MVAG-3.8 Stripping Blade	23290	0.14961	3.80	6.013.0529.538
MVAG-4.0 Stripping Blade	23291	0.15748	4.00	6.013.0530.540
MVAG-4.2 Stripping Blade	23292	0.16535	4.20	6.013.0531.542
MVAG-4.4 Stripping Blade	23293	0.17323	4.40	6.013.0532.544
MVAG-4.6 Stripping Blade	23294	0.18110	4.60	6.013.0533.546
MVAG-4.8 Stripping Blade	23295	0.18898	4.80	6.013.0534.548
MVAG-5.0 Stripping Blade	23296	0.19685	5.00	6.013.0535.550

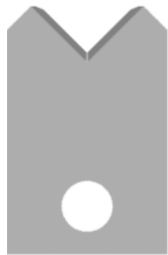

MVCE Cut-off Blades

Mechtrix Description	Mechtrix Part Number	Blade Form Diameter		OEM Part Number
		(in)	(mm)	
MVCE Cut-off Blade	13617-CT1	-	-	6.013.0184.400

ASM-3XXX Series Blades

Used in the following Schäfer / Megomat machines:

ASM-3XXX

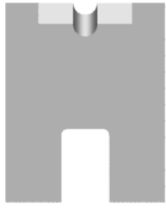

Standard "MDE" Tooling Setup

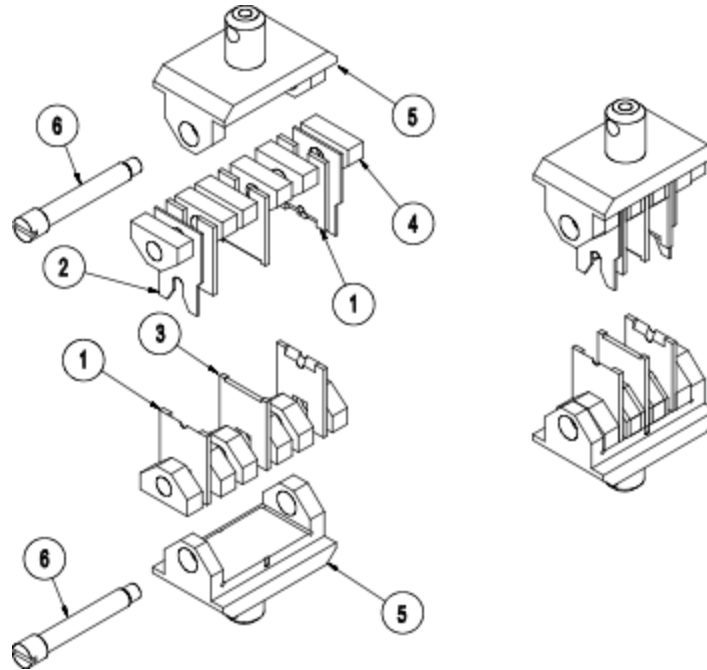

No.	Part Description	Qty.	No.	Part Description	Qty.
1	MDE Stripping Blade	4	5	ASM-3XXX Toolholder	2
2	MDGE Wire Guide	2	6	ASM-3XXX Toolholder Pin	2
3	MDCE Cut-off Blade	2			
4	ASM-3XXX Spacer	-			



MDCE Cut-off Blades

Mechtrix Description	Mechtrix Part Number	Blade Form (in)	Diameter (mm)	OEM Part Number
MDCE Cut-off Blade	13099	-	-	6.013.0183.400

ASM-3XXX Series Blades

Used in the following Schäfer / Megomat machines:

ASM-3XXX

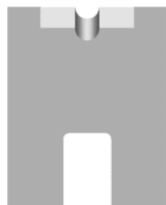

MDE Stripping Blades

Mechtrix Description	Mechtrix Part Number	Blade Form (in)	Diameter (mm)	OEM Part Number
MDE-0.4 Stripping Blade	18849	0.01575	0.40	6.013.0250.404
MDE-0.5 Stripping Blade	16569	0.01969	0.50	6.013.0251.405
MDE-0.6 Stripping Blade	16292	0.02362	0.60	6.013.0252.406
MDE-0.7 Stripping Blade	14649	0.02756	0.70	6.013.0253.407
MDE-0.8 Stripping Blade	14861	0.03150	0.80	6.013.0254.408
MDE-0.9 Stripping Blade	13611	0.03543	0.90	6.013.0255.409
MDE-1.0 Stripping Blade	14333	0.03937	1.00	6.013.0256.410
MDE-1.1 Stripping Blade	15767	0.04331	1.10	6.013.0257.411
MDE-1.2 Stripping Blade	13427	0.04724	1.20	6.013.0258.412
MDE-1.3 Stripping Blade	14648	0.05118	1.30	6.013.0259.413
MDE-1.4 Stripping Blade	13612	0.05512	1.40	6.013.0260.414
MDE-1.5 Stripping Blade	13428	0.05906	1.50	6.013.0261.415
MDE-1.6 Stripping Blade	13613	0.06299	1.60	6.013.0262.416
MDE-1.7 Stripping Blade	13681	0.06693	1.70	6.013.0263.417
MDE-1.8 Stripping Blade	13614	0.07087	1.80	6.013.0264.418
MDE-1.9 Stripping Blade	13301	0.07480	1.90	6.013.0265.419
MDE-2.0 Stripping Blade	13936	0.07874	2.00	6.013.0266.420
MDE-2.1 Stripping Blade	13615	0.08268	2.10	6.013.0266.421
MDE-2.2 Stripping Blade	13616	0.08661	2.20	6.013.0267.422
MDE-2.3 Stripping Blade	14707	0.09055	2.30	-
MDE-2.4 Stripping Blade	13835	0.09449	2.40	6.013.0268.424
MDE-2.5 Stripping Blade	14808	0.09843	2.50	-
MDE-2.6 Stripping Blade	15312	0.10236	2.60	6.013.0269.426
MDE-2.7 Stripping Blade	15313	0.10630	2.70	-
MDE-2.8 Stripping Blade	13192	0.11024	2.80	6.013.0270.428
MDE-2.9 Stripping Blade	14809	0.11417	2.90	-
MDE-3.0 Stripping Blade	13193	0.11811	3.00	6.013.0271.430
MDE-3.1 Stripping Blade	16284	0.12205	3.10	-
MDE-3.2 Stripping Blade	13194	0.12598	3.20	6.013.0272.432
MDE-3.3 Stripping Blade	16285	0.12992	3.30	-
MDE-3.4 Stripping Blade	14810	0.13386	3.40	6.013.0273.434
MDE-3.5 Stripping Blade	16286	0.13780	3.50	-
MDE-3.6 Stripping Blade	13195	0.14173	3.60	6.013.0274.436
MDE-3.7 Stripping Blade	16287	0.14567	3.70	-
MDE-3.8 Stripping Blade	13196	0.14961	3.80	6.013.0275.438
MDE-3.9 Stripping Blade	16288	0.15354	3.90	-
MDE-4.0 Stripping Blade	15988	0.15748	4.00	6.013.0276.440
MDE-4.1 Stripping Blade	16289	0.16142	4.10	-
MDE-4.2 Stripping Blade	15989	0.16535	4.20	6.013.0277.442
MDE-4.3 Stripping Blade	18298	0.16929	4.30	-
MDE-4.4 Stripping Blade	18850	0.17323	4.40	6.013.0278.444
MDE-4.5 Stripping Blade	18300	0.17717	4.50	-
MDE-4.6 Stripping Blade	18851	0.18110	4.60	6.013.0279.446
MDE-4.7 Stripping Blade	18302	0.18504	4.70	-
MDE-4.8 Stripping Blade	18852	0.18898	4.80	6.013.0280.448
MDE-4.9 Stripping Blade	18304	0.19291	4.90	-
MDE-5.0 Stripping Blade	18853	0.19685	5.00	6.013.0281.450

ASM-3XXX Series Blades

Used in the following Schäfer / Megomat machines:

ASM-3XXX



MDGE Wire Guides

Mechtrix Description	Mechtrix Part Number	Guide Form (in)	Diameter (mm)	OEM Part Number
MDGE-0.6 Wire Guide	18854	0.02362	0.60	6.013.0300.406
MDGE-0.7 Wire Guide	18855	0.02756	0.70	6.013.0301.407
MDGE-0.8 Wire Guide	18856	0.03150	0.80	6.013.0302.408
MDGE-0.9 Wire Guide	18857	0.03543	0.90	6.013.0303.409
MDGE-1.0 Wire Guide	18858	0.03937	1.00	6.013.0304.410
MDGE-1.1 Wire Guide	18859	0.04331	1.10	6.013.0305.411
MDGE-1.2 Wire Guide	16293	0.04724	1.20	6.013.0306.412
MDGE-1.3 Wire Guide	16610	0.05118	1.30	6.013.0307.413
MDGE-1.4 Wire Guide	15504	0.05512	1.40	6.013.0308.414
MDGE-1.5 Wire Guide	14708	0.05906	1.50	6.013.0309.415
MDGE-1.6 Wire Guide	15380	0.06299	1.60	6.013.0310.416
MDGE-1.7 Wire Guide	15381	0.06693	1.70	6.013.0311.417
MDGE-1.8 Wire Guide	15382	0.07087	1.80	6.013.0312.418
MDGE-1.9 Wire Guide	15383	0.07480	1.90	6.013.0313.419
MDGE-2.0 Wire Guide	15384	0.07874	2.00	6.013.0314.420
MDGE-2.1 Wire Guide	13785	0.08268	2.10	6.013.0315.421
MDGE-2.2 Wire Guide	13757	0.08661	2.20	6.013.0316.422
MDGE-2.3 Wire Guide	15385	0.09055	2.30	6.013.0317.423
MDGE-2.4 Wire Guide	13786	0.09449	2.40	6.013.0318.424
MDGE-2.5 Wire Guide	15386	0.09843	2.50	6.013.0319.425
MDGE-2.6 Wire Guide	14709	0.10236	2.60	6.013.0320.426
MDGE-2.7 Wire Guide	15387	0.10630	2.70	6.013.0321.427
MDGE-2.8 Wire Guide	15314	0.11024	2.80	6.013.0322.428
MDGE-2.9 Wire Guide	15388	0.11417	2.90	6.013.0323.429
MDGE-3.0 Wire Guide	13302	0.11811	3.00	6.013.0324.430
MDGE-3.1 Wire Guide	18285	0.12205	3.10	-
MDGE-3.2 Wire Guide	15315	0.12598	3.20	6.013.0325.432
MDGE-3.3 Wire Guide	18286	0.12992	3.30	-
MDGE-3.4 Wire Guide	15316	0.13386	3.40	6.013.0326.434
MDGE-3.5 Wire Guide	16714	0.13780	3.50	-
MDGE-3.6 Wire Guide	14933	0.14173	3.60	6.013.0327.436
MDGE-3.7 Wire Guide	18287	0.14567	3.70	-
MDGE-3.8 Wire Guide	15317	0.14961	3.80	6.013.0328.438
MDGE-3.9 Wire Guide	18288	0.15354	3.90	-
MDGE-4.0 Wire Guide	15318	0.15748	4.00	6.013.0329.440
MDGE-4.1 Wire Guide	18289	0.16142	4.10	-
MDGE-4.2 Wire Guide	13758	0.16535	4.20	6.013.0330.442
MDGE-4.3 Wire Guide	18290	0.16929	4.30	-
MDGE-4.4 Wire Guide	16052	0.17323	4.40	6.013.0331.444
MDGE-4.5 Wire Guide	16435	0.17717	4.50	-
MDGE-4.6 Wire Guide	16053	0.18110	4.60	6.013.0332.446
MDGE-4.7 Wire Guide	18291	0.18504	4.70	-
MDGE-4.8 Wire Guide	16054	0.18898	4.80	6.013.0333.448
MDGE-4.9 Wire Guide	18292	0.19291	4.90	-
MDGE-5.0 Wire Guide	18293	0.19685	5.00	6.013.0334.450
MDGE-5.1 Wire Guide	18294	0.20079	5.10	-
MDGE-5.2 Wire Guide	16715	0.20472	5.20	6.013.0335.452
MDGE-5.3 Wire Guide	18295	0.20866	5.30	-
MDGE-5.4 Wire Guide	18296	0.21260	5.40	6.013.0336.454