



MECHTRIX

WIRE
PREFEEDING
EQUIPMENT

MPF-33 Wire Prefeeding System



■ APPLICATIONS:

The Mechtrix MPF-33 Wire Prefeeding System removes wire from reels or barrels and makes up to 25' (7.5m) of wire immediately available to a wire processing machine. The MPF-33 has been specifically designed and configured for use with programmable bench top wire processing machines pulling wire up to 16.5'/sec (5m/sec).

■ METHOD OF OPERATION:

The MPF-33 Prefeeder operating control system utilizes the Mechtrix Auto-Tune® System. The prefeeder's motor speed is continually and automatically adjusted via a linear transducer that monitors the position of the accumulating pulleys. This feature eliminates the need for operator motor speed adjustments and insures smooth operation of the prefeeder. Wire is removed from the reel or barrel by an integrated variable speed DC drive motor and gear reducer drive system and fed into the accumulation pulleys. The vertical wire accumulation pulleys feature pneumatically adjustable tension to control all the wire in the draw source.

■ SPECIAL FEATURES:

- Pneumatic adjustable wire back-tension system adjusts from 20oz. to 12lbs. (0.57kg to 5.4kg).
- Wire de-reeling speed is automatically adjusted via the Mechtrix Auto-Tune® control system to minimize the amount of stress on the wire.
- Unique pneumatic wire dampening and shock absorbing device minimizes wire feed errors inherent in other prefeeder designs.
- Simple set-up and change-over process with retractable wire guards that make wrapping wire around the pulleys fast and easy.
- Vertical design reduces floor space requirements.
- Integrated wire lifting device makes loading and un-loading of reels quick and safe.

■ MPF-33 CONFIGURATION OPTIONS:

Wire Feed Orientation:

- MPF-33's are available in Left-to-Right or Right-to-Left configurations.

Mechtrix MPF-33 Wire Prefeeding System with Integrated Reel Lift Device

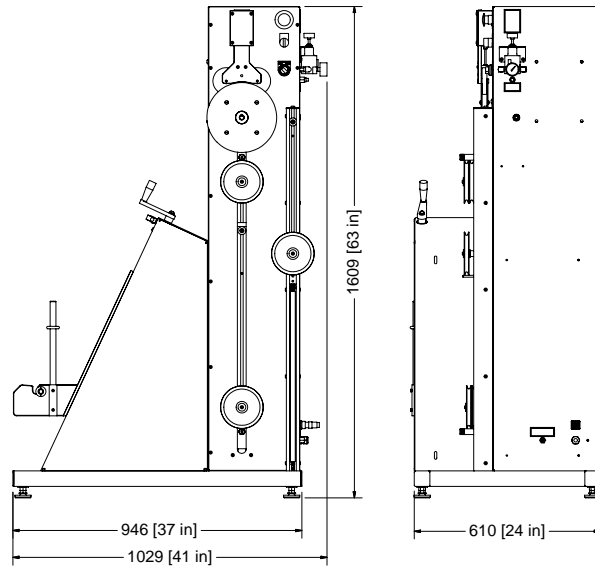

MPF-33 OPTIONS:

Reel Centering Cones:

- Reel centering cones are available for wire reels which have center hub holes that are larger than the standard 0.625" reel support shaft. These cones allow for smoother operation when running this type of wire reel. The adjusted maximum reel sizes when using cones are listed below.

Part Number	Description	Wire Reel Hole Diameter Range	Maximum Reel Width w/Cones Installed
26552-501	3" Diameter Reel Centering Cone Set	1.00" to 2.75" Diameter	1.00" Diameter Hole = 16" Wide 1.75" Diameter Hole = 17" Wide 2.75" Diameter Hole = 18" Wide
26553-501	4" Diameter Reel Centering Cone Set	2.75" to 3.75" Diameter	2.75" Diameter Hole = 17" Wide 3.75" Diameter Hole = 18" Wide
26554-501	5" Diameter Reel Centering Cone Set	3.75" to 4.75" Diameter	3.75" Diameter Hole = 17" Wide 4.75" Diameter Hole = 18" Wide
27985-501	6" Diameter Reel Centering Cone Set	4.75" to 5.75" Diameter	4.75" Diameter Hole = 17" Wide 5.75" Diameter Hole = 18" Wide

TECHNICAL DATA:

Max Wire Reel Size and Weight:

- 18" wide x 34" diameter (400lbs)
- 457mm wide x 864mm diameter (180kg)

* Reel bore size and centering cones can reduce the maximum wire reel size. Machine performance may decrease significantly when running spools larger than 16" (405mm) diameter or weighing more than 100lbs (45kg).

* The MPF-33's maximum wire pulling force is 32lbs (14.5kg).

Wire Draw Source Capacity:

- 25ft (7.5m)

MPF-33 Top Feed Speed:

- 11ft/sec (3.3m/sec)

Machine Weight:

- 263lbs (119kg)

Motor Type:

- DC-Motor

Motor Control:

- Mechtrix Auto-Tune® System

Electrical Requirements:

- 115VAC, 10AMP, 60Hz
- 230VAC, 10AMP, 50Hz

Pneumatic Requirements:

- 0.5CFM@60PSI (14.1l/min@0.4Mpa)